



Rev. A

Issued: 04/15/2005



Meltric Corporation  
4640 Ironwood Drive  
Franklin, WI 53132  
(800)433-7642  
www.meltric.com

**GENERAL**

Meltric's DXN Series plugs & receptacles are designed and rated for use in hazardous environments where explosive gases or dusts may be present.

The DXN receptacle has a dead front, which isolates the supply contacts and prevents user exposure to live parts. The safety shutter blocking access to the contacts can be opened only by DXN plugs with compatible ratings and contact configurations.

DXN's that are equipped with optional auxiliary contacts can be electrically interlocked with motor controllers or other devices when the auxiliary contacts are used as pilot contacts.

**RATINGS & CERTIFICATIONS**

To ensure the safe use of this product, the installer must verify that the product is properly rated for the application.

**Electrical**

The amperage and voltage ratings are indicated on the device labels.

**Hazardous Duty**

DXN plugs & receptacles have both ATEX and cCSAus ratings for use in hazardous environments.

**ATEX – Class 1 Zone 1 AEx ed IIC T6**

This rating certifies the product for use in surface (non-underground) applications where a high level of protection is required and where the presence of an explosive atmosphere of any type of gas or dust is likely to occur. The associated maximum surface temperature of the product is 85°C, at an ambient temperature of 40°C.

**cCSAus – Class 1 Division 2 Group A, B, C, D  
Class 2 Division 2 Group E, F, G**

This rating certifies the product for use in applications where flammable gases, such as Acetylene, hydrogen, ethylene or propane, or dusts, such as magnesium, coal or grain, may be present under abnormal conditions.

**Ingress Protection**

DXN's have an IP 66/67 rating for protection against ingress of water, dust and other matter. IP 66 provides total protection against dust and water jets. IP 67 adds protection for temporary immersion in shallow water.

These ratings apply when the plug and receptacle are mated. They also apply to the receptacle alone, provided that its lid is latched in the closed position. Optional plug caps are available for providing IP 66/67 protection on unmated plugs.

**INSTALLATION**

DXN's must be used in conjunction with other appropriately rated hazardous duty products and must be installed by qualified electricians in accordance with all applicable local and national electrical codes. Before starting, ensure that the power is off and verify that the conductors meet the requirements of the National Electric Code and are within the capacities of the DXN terminals noted in Table 1.

**Table 1 - Conductor Size Capacity - AWG**

	Main Contacts		Aux. Contacts	
	Max	Min	Max	Min
DXN1	10	20	-	-
DXN3	8	14	12	20
DXN6	3	10	12	20

Other sizes may be used in conjunction with appropriate wiring ferrules.

**Assembly for In-line Connections**

When DXN's are used as in-line connectors, finger drawplates should be installed on both the receptacle and plug in order to more easily provide the leverage required to properly connect the devices.

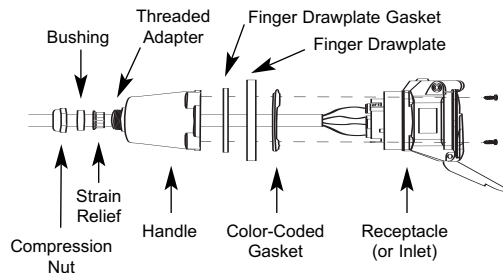

Adjust the bushing diameter to fit the cable by removing inner sections of it as required. Loosely re-assemble the compression nut, bushing and strain relief to the threaded adapter on the end of the handle and insert the cable through it, the thin black drawplate gasket and finger drawplate (if applicable), and the color-coded gasket. Being mindful that the strain relief must clamp on the cable sheath, strip the cable sheath as required to provide a workable wire length. Then strip the individual wires to the lengths indicated in Table 2, and twist the strands of each conductor together.



**Table 2 - Wire Strip Length - A**

	Inches	mm
DXN1 - All	0.50	12
DXN3 - Main	0.75	20
DXN3 - Aux.	0.75	17
DXN6 - Main	0.75	20
DXN6 - Aux	0.75	18

Back out the terminal screws on the receptacle (or inlet) far enough (but not completely) to allow the conductors to pass, insert the conductors fully into their respective terminals and tighten the terminal screws with a hand screwdriver to the torque indicated in Table 3.

**Table 3 - Recommended Tightening Torques**

Terminal	Torque	Flat Screwdriver
DXN1	10.6 in-lbs	1/8" precision tip
DXN3 (Main Contacts)	10.6 in-lbs	3/16" precision tip
DXN3 (Aux. Contacts)	10.6 in-lbs	1/8" precision tip
DXN6 (Main Contacts)	22.0 in-lbs	3/16" precision tip
DXN6 (Aux. Contacts)	10.6 in-lbs	1/8" precision tip

DXN terminals are spring assisted to prevent loosening due to strand settlement, vibration and thermal cycling. Do not over-tighten.

Verify that the cable sheath will extend beyond the strain relief and into the handle. Assemble the receptacle (or inlet), the color-coded gasket, the finger drawplate, and the thin black finger drawplate gasket to the handle with the four self-tapping screws provided. **(CAUTION** – over-tightening the screws may cause cracking in polymeric components). Adjust the cable location so that it will not be under tension inside the handle and tighten the compression nut to secure the cable.

**Assembly for Mounted Receptacles (or Inlets)**

In applications where DXN receptacles (or inlets) are mounted to wall boxes, panels or other equipment, optimal operation is achieved when the device is installed with the latch at the top.

**NOTE:** If the device is mounted to a wall box, make sure that appropriate hole plugs are securely tightened in any unused connection holes.

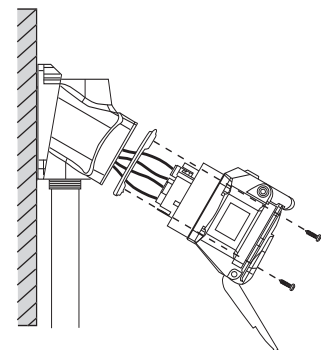

Insert the cable or wires through the wall box and cut to allow adequate length, strip the cable sheath, as desired, strip the individual wires to the lengths indicated in Table 2, and twist the strands of each conductor together. Back out the terminal

screws on the receptacle (or inlet) far enough (but not completely) to allow the conductors to pass, insert the conductors fully into their respective terminals and tighten the terminal screws to the torque indicated in Table 3, with a hand screwdriver.

Assemble the receptacle (or inlet) and the color-coded gasket to the box with appropriate hardware. **(CAUTION** – over-tightening the screws may cause cracking in polymeric components). Assemble the mating plug (or receptacle) to the cord end as indicated in the assembly instructions above for in-line connections, except there will be no finger drawplate or associated black gasket.

In cases where custom mounting is being performed to an appropriate hazardous duty box or panel, the clearance and mounting holes should be drilled as indicated in the following diagram.

### Hole Pattern for Custom Mounting

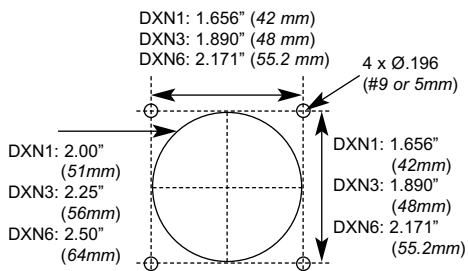

In order to maintain IP66/67 protection in custom installations, watertight seals must be used under the heads of the four mounting bolts and they must be retained by a lock washer and nut on the inside of the box or panel. Alternatively, four blind holes can be drilled and threaded to accommodate #8-32 x 5/8" mounting screws. The hole depth must be sufficient to achieve adequate gasket compression.

### OPERATION

To ensure safe and reliable operation, Meltric plugs and receptacles must be used in accordance with their assigned ratings. They can only be used in conjunction with mating receptacles or plugs manufactured by Meltric or another licensed producer of products bearing the **Meltric** trademark.

Meltric plugs & receptacles are designed with different keying arrangements, so that only plugs and receptacles with compatible contact configurations and electrical ratings will mate with each other.

### Connection

To connect a plug and receptacle, first depress the pawl to open the lid on the receptacle, then orient the plug **1** so that the red dot on the outside of the casing lines up with the red dot just to the left of the latch on the receptacle casing. Push the plug partially into the receptacle until it hits a stop, then rotate the plug in the clockwise direction until it hits another stop after about 30° of rotation. At this point, the circuit is still open. Push the plug straight into the receptacle **2** until it becomes securely latched in place. The connection is now made. On in-line connectors, squeeze the drawplates on both sides of the device together until the plug latches in place.

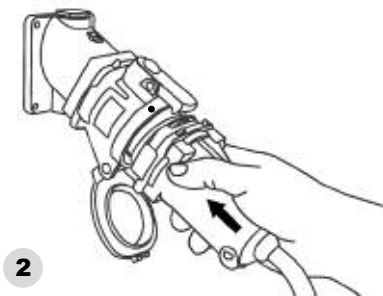
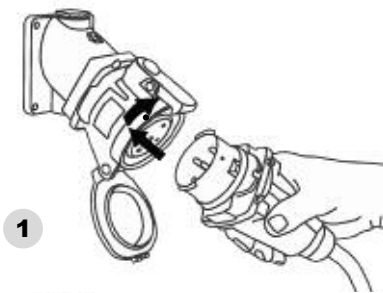

### Disconnection

To break the connection, depress the pawl and simultaneously pull the plug straight out **3** to the rest position. The circuit is broken. To withdraw the plug, simply rotate it counter-clockwise (about 30°) until it releases from the receptacle **4**. Close and latch the lid on the receptacle.

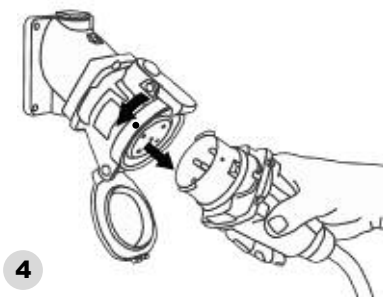
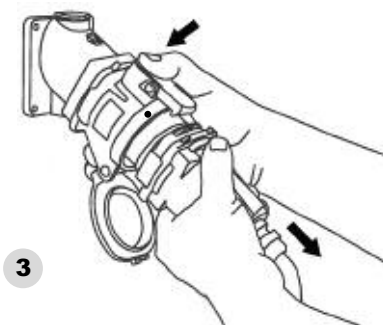

### Partial Compatibility with the DSN Series

All DXN1 plugs and DXN3 plugs without auxiliary contacts are compatible with similarly rated Meltric DSN1 and DSN3 series receptacles for non-hazardous locations. This allows hazardous location equipment to additionally be used in non-hazardous areas. DXN6 plugs do not have similar compatibility with DSN6 receptacles.

### Lockout Provisions

All DXN plugs are provided with lockout provisions. To lockout the plug, insert the locking device through the hole provided in the casing. This will prevent the plug from being able to be inserted into a receptacle.

DXN's may also be purchased with optional lockout provisions for the receptacle. To lockout the receptacle, close and latch the lid and then attach the locking device through the hole provided in the latch. This will prevent the lid from being opened.

**NOTE:** Attaching the receptacle locking device with the lid open will not prevent the insertion of a plug. Lockout is only accomplished when the lid is locked closed.

### MAINTENANCE

Meltric products require little on-going maintenance. However, it is a good practice to periodically perform the following general inspections:

- Check the mounting screws for tightness.
- Verify that the weight of the cable is supported by the strain relief mechanism and not by the terminal connections.
- Check the IP gaskets for wear and resiliency. Replace as required.
- Verify the electrical continuity of the ground circuit.
- Check the contact surfaces for cleanliness and pitting.

Deposits of dust or similar foreign materials can be rubbed off the contacts with a clean cloth. Sprays should not be used, as they tend to collect dirt. If any significant pitting of the contacts or other serious damage is observed, the device should be replaced.

### MANUFACTURER'S RESPONSIBILITY

Meltric's responsibility is strictly limited to the repair or replacement of any product that does not conform to the warranty specified in the purchase contract. Meltric shall not be liable for any penalties or consequential damages associated with the loss of production, work, profit, or any other kind of financial loss incurred by the customer.

Meltric Corporation shall not be held liable when its products are used in conjunction with products not bearing the **Meltric** trademark. The use of Meltric products in conjunction with mating devices that are not marked with the **Meltric** trademark shall void all warranties on the product.

Meltric Corporation is a member of the international association, **BECMA: the Butt-contact Electrical Connectors Manufacturers Association.**

